

3252 & 3262 HOLIDAY COURT

LA JOLLA, CALIFORNIA 92037

LA JOLLA
CORPORATE
CENTER



OFFICE / MEDICAL FOR LEASE

JON BOLAND, PARTNER

SENIOR VICE PRESIDENT ▪ LIC #00999843
(858) 458-3312 ▪ jboland@voitco.com

RYAN BRACKER, PARTNER

VICE PRESIDENT ▪ LIC #01353870
(858) 458-3355 ▪ rbracker@voitco.com



▪ [CLICK IMAGE TO VIEW PROPERTY TOUR](#) ▪

LA JOLLA CORPORATE CENTER

PROJECT FEATURES



COVERED PARKING AVAILABLE (\$75/STALL)
FREE SURFACE LEVEL PARKING



FOOD, FITNESS, HOTEL, ENTERTAINMENT
& SHOPPING WITHIN WALKING DISTANCE

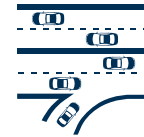

EXCELLENT VISIBILITY & FREEWAY ACCESS



TRANSIT ORIENTED WITHIN WALKING
DISTANCE TO THE TROLLEY & BUS STOP



DIRECT CONNECTION TO UCSD & VA MEDICAL
CENTER WITHIN WALKING DISTANCE

Asking Rate

Office: \$3.15 FSG/SF/Mo. | Medical: \$4.00 FSG/SF/Mo.



LA JOLLA
CORPORATE
CENTER

PROPERTY PHOTOS

LA JOLLA CORPORATE CENTER

3252 HOLIDAY COURT AVAILABILITY

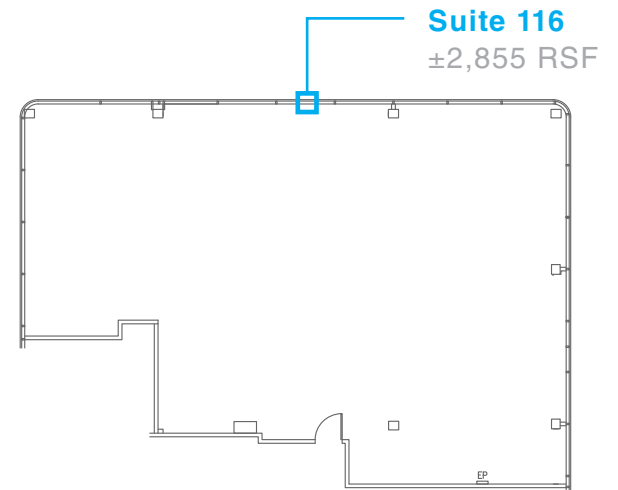
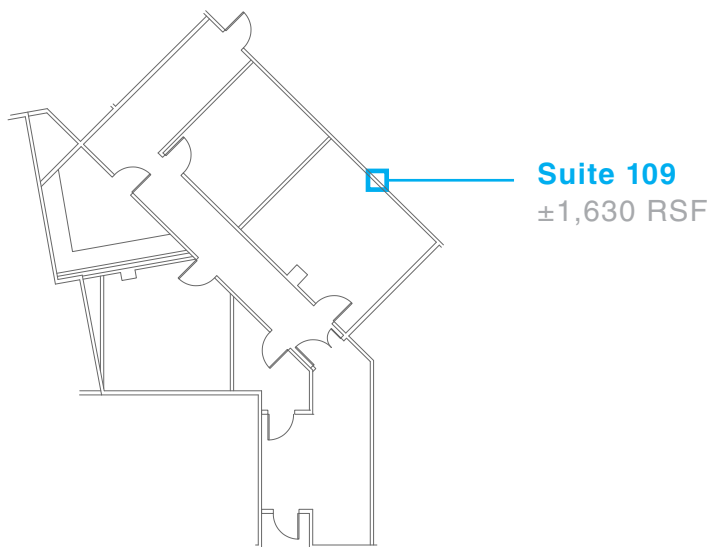
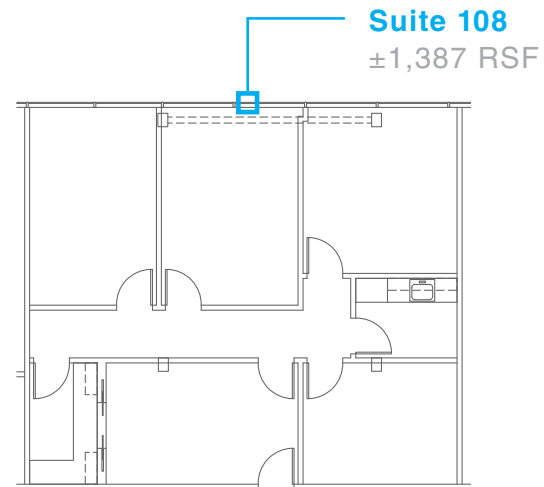
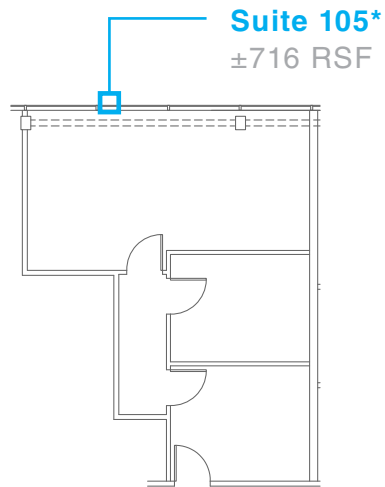

LA JOLLA CORPORATE CENTER

3252 HOLIDAY COURT AVAILABILITY

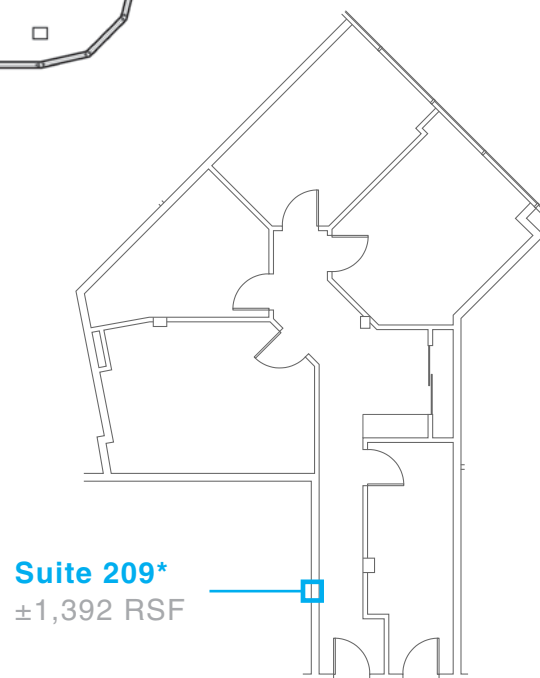
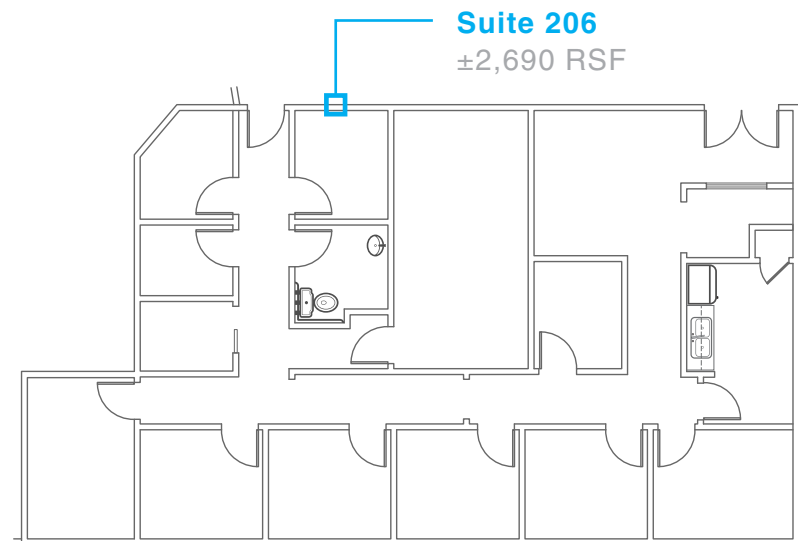
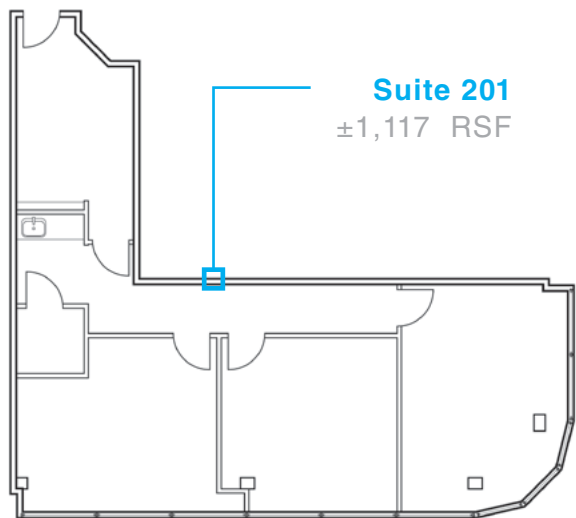

LA JOLLA CORPORATE CENTER

3262 HOLIDAY COURT AVAILABILITY

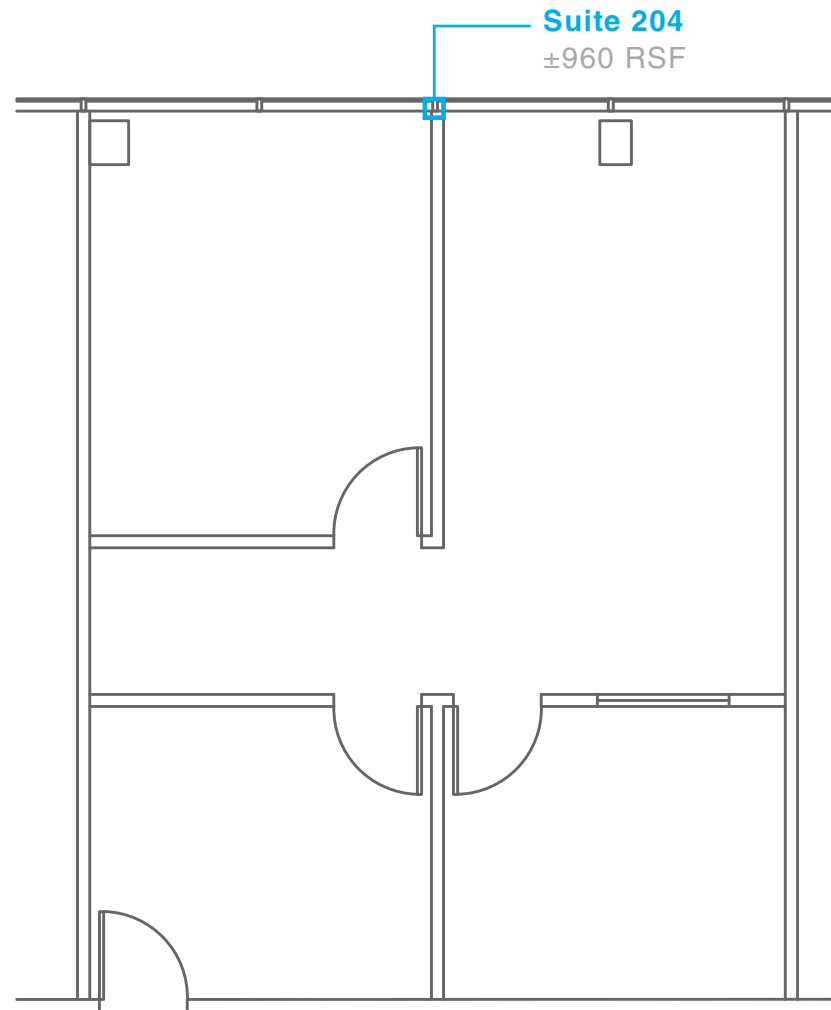

LA JOLLA CORPORATE CENTER

PROPERTY PHOTOS



3252

HOLIDAY COURT



3262

HOLIDAY COURT



LA JOLLA CORPORATE CENTER

WALKABLE AMENITIES

SHOPS AT LA JOLLA VILLAGE



LA JOLLA VILLAGE SQUARE



LA JOLLA CORPORATE CENTER

NOBEL TRANSIT CENTER

6 MINUTE WALK TO LA JOLLA CORPORATE CENTER



TROLLEY TIME

BLUE LINE TROLLEY STOPS

DISTANCE TO LJCC

0

MIN.

LA JOLLA CORPORATE CENTER
TO NOBLE DRIVE STATION

0.5

MILES

2

MIN.

LA JOLLA CORPORATE CENTER
TO VA MEDICAL CENTER

1.2

MILES

9

MIN.

LA JOLLA CORPORATE CENTER
TO UTC TRANSIT CENTER

2.2

MILES

17

MIN.

LA JOLLA CORPORATE CENTER
TO OLD TOWN TRANSIT CENTER

9.2

MILES

26

MIN.

LA JOLLA CORPORATE CENTER
TO SANTA FE DEPOT (DOWNTOWN)

12.8

MILES



TORREY PINES

LA JOLLA

NORTH TORREY PINES ROAD



the Campus
ON VILLA LA JOLLA

GILMAN DRIVE

VIA LA JOLLA DRIVE

NOBEL DRIVE

la jolla
VILLAGE SQUARE

THE SHOPS
AT LA JOLLA VILLAGE

SUBJECT

LA JOLLA VILLAGE DRIVE

VA San Diego
HEALTHCARE SYSTEM

VOIGHT DRIVE



JON BOLAND, PARTNER

SENIOR VICE PRESIDENT ▪ LIC #00999843
(858) 458-3312 ▪ jboland@voitco.com

RYAN BRACKER, PARTNER

VICE PRESIDENT ▪ LIC #01353870
(858) 458-3355 ▪ rbracker@voitco.com



REAL ESTATE SERVICES

4180 La Jolla Village Drive, Suite 100, La Jolla, CA 92037 • 858.453.0505 • 858.408.3976 Fax • Lic #01991785 • www.VoitCo.com

[VOIT TOURING GUIDELINES >>](#)

Licensed as a Real Estate Salespersons by the DRE. ©2022 Voit Real Estate Services, Inc. All Rights Reserved. The information contained herein has been obtained from sources we deem reliable. While we have no reason to doubt its accuracy, we do not guarantee it.